

Horizon



BQ-470

Perfect Binder

**Drastic Advances in Binding Process
Full Automated, 4-Clamp Perfect Binder**



The Horizon BQ-470 Fully Automated, 4-Clamp Perfect Binder features an interchangeable glue tank for both EVA and PUR adhesives.

Features

- Fully automated set-up through the intuitive icon based LCD touchscreen.
- Customer replaceable glue tank unit for both EVA hotmelt and PUR hotmelt adhesives to meet varying customer requirements.
- Simplified and accurate changeover to produce professionally finished books.
- Equipped with two large application rollers for strong, high-quality binds and a separate side glue tank for added flexibility.
- Space-saving design with front operation and front maintenance.
- Book-binding up to 65 mm / 2.55" thickness.
- Easily operated by anyone in the bindery. Maximum cycle speed is 1,350 books per hour (EVA hotmelt glue).
- Ergonomic sliding windows provide easy, safe access and a clear view of operations.



Key Features

Color Touchscreen

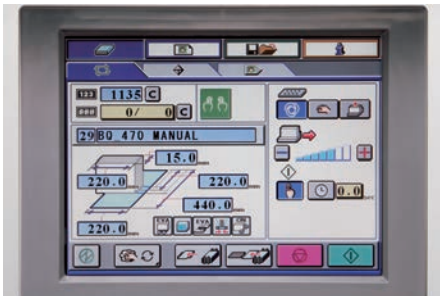

The 10.4 inch large color touchscreen maximizes ease of operation. Trouble-shooting screen helps operator maintain smooth production.

Milling Lever

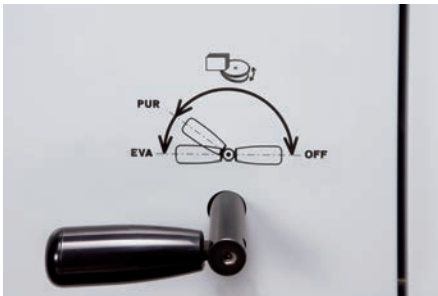

Three different milling styles can be selected: Milling Off, Milling for EVA or Milling for PUR.

Nipping Height Adjustment

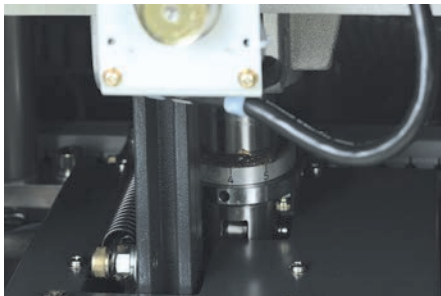

A strong, rigid nipping mechanism ensures high quality binding. The nipping height is simple and easy to adjust.



Suction Cover Feed

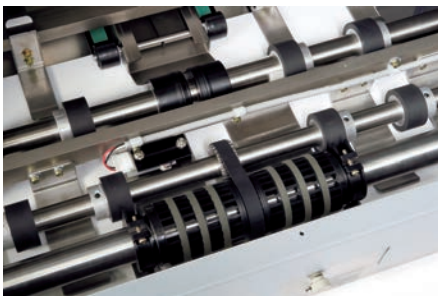

The advanced rotary suction feed system insures faster production. A wide range of cover sheets can be handled without any marking.

Supersonic Double Feed Detect Sensor

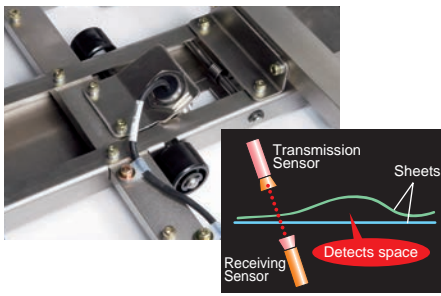

The supersonic double feed detect sensor comes standard. Advanced detection with supersonic sensor ensures accurate double feed detection even with a solid black printed sheet.

Delivery Conveyor



The automated elevation conveyor can stack books up to 300 mm / 11.8" high. The jogging table is attached to the conveyor for efficient operation.

Smoke Extractor

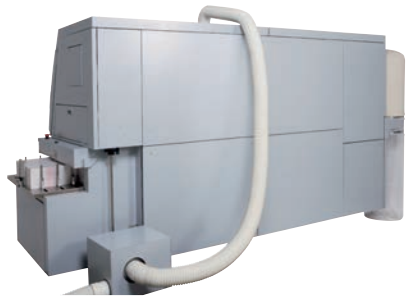

Extracts fumes of hotmelt glue for comfortable working conditions.

Automated set-ups ensure user-friendly operation and professional binding.

End-to-end Automated Set-up

- Carriage Clamp Width at book feeding section ①
- Guide Width at milling section ②
- Side Gluing Roller Width at glue tank unit ③
- Glue Length (Top-Bottom) at glue tank unit ③
- Wiper Opening for Glue Amount (First Application Roller/ Second Application Roller) at glue tank unit ③
- Spine Glue Thickness (Second Application Roller Height) at glue tank unit ③
- Nipping Width at nipping section ④
- Guide Width (Fore-edge) at cover registration section ⑤
- Cover Tail Edge Positioner at cover registration section ⑤
- Scoring Position (4 lines) at scoring section ⑥
- Guide Width at cover feeding section ⑦
- Guide Width at book delivery section ⑧

① Book Feeding Section



Automated Point Carriage Clamp Width

A rigid clamping system holds the book block firmly in position during the milling and nipping process to produce a quality finished book. The safety beam ensures risk-free operation.

② Milling Section

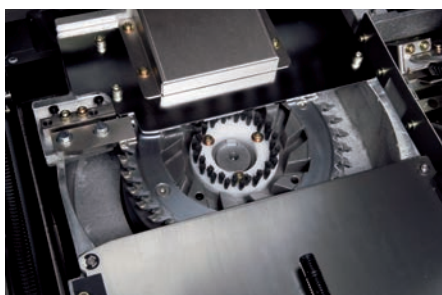

Automated Point Guide Width

Powerful servo motor driven milling and notching mechanism mills the spine of a book block or signature for optimum glue penetration and adherence. Milling depth can be adjusted from 0 to 4 mm (0" to 0.157").

③ Glue Tank Unit

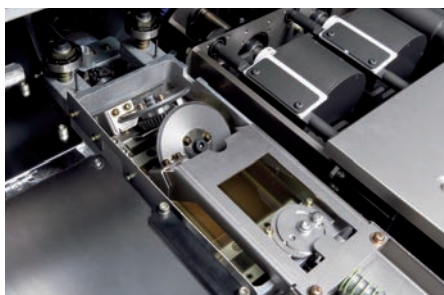

Automated Point Spine Glue: Glue Length (Top-Bottom), Wiper Opening for Glue Amount (First Application Roller/Second Application Roller), Spine Glue Thickness (Second Application Roller Height), Side Glue: Side Gluing Roller Width

Dual application rollers and side gluing rollers ensure superior glue application to the spine for quality binding.

④ Nipping Section

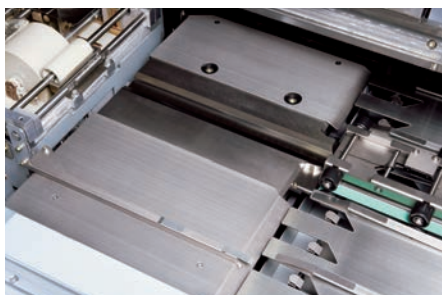

Automated Point Nipping Width

A strong rigid nipping mechanism guarantees precise alignment of the cover to the book block. The nipping operating time and nipping delay time can be set up through the LCD touchscreen.

⑤ Cover Registration Section



Automated Point Guide Width (Fore-edge), Cover Tail Edge Positioner

After transport to the nipping section, the cover is registered precisely with the fore-edge guide and tail edge positioner.





6 Scoring Section

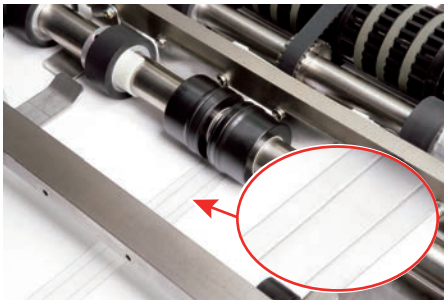

Automated Point Scoring Position (4 lines)

The scoring width and position are automatically set up through the LCD touchscreen. Scoring is performed on thick covers for professional binding with sharp, square spine corners.

7 Cover Feeding Section

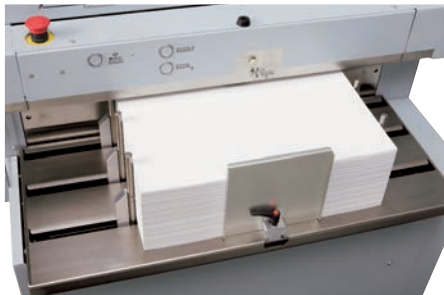

Automated Point Guide Width

The high capacity cover feed station has a maximum pile height of 150 mm / 5.9" for continuous binding operation. The cover feeder can handle a wide range of cover stocks from 81.4 to 302.4 gsm of normal paper or 104.7 to 348.9 gsm of coated paper.

8 Book Delivery Section

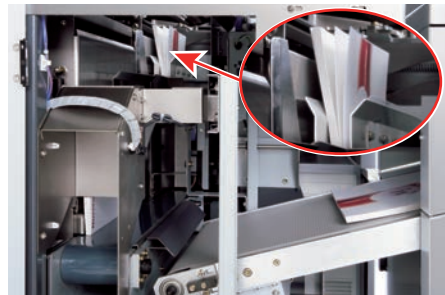

Automated Point Guide Width

The delivery section employs an elevation conveyor so that the bound books are gently received and transported to the stacker without damage to the book spine.

PUR Tank and EVA Tank

The BQ-470 incorporates the remarkable PUR binding mechanism and features an interchangeable glue tank, for both EVA and PUR adhesives.



PUR
MU-470PUR
 Polyurethane reactive adhesive suitable for coated stock. Lay-flat binding can be performed.

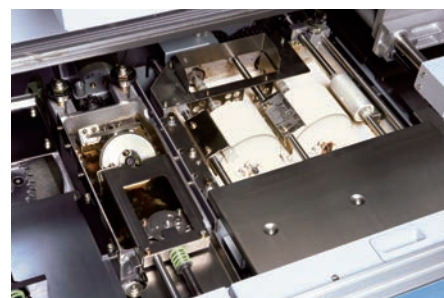

EVA
MU-470EVA
 Commonly used for all kinds of binding. The melted glue can be used repeatedly so there's no need to clean up the tank after operation.

Cleaning and Replacement of MU-470PUR



The application drums and back spinner lift and latch to provide easy access for cleaning of the tank.



Install the special drain for glue run-off. The PUR tank and drums are Teflon coated so that the remaining glue can be easily peeled off after cooling.



Sliding glue tank for easy replacement. Pull out the tank and remove it with the optional special lifter.

Strong, Environmentally Friendly PUR Solution

Polyurethane Reactive, also called PUR, is a polyurethane adhesive attracting attention for binding strength and eco-friendliness.

Strong and Lay-Flat Binding

As the printing industry diversifies, there is growing demand for binding with color sheets. EVA hotmelt glue has difficulty binding coated stock firmly, and does not currently enable acceptable lay-flat binding. However, PUR hotmelt glue can provide adequate binding strength and lay-flat quality for both offset and digital prints.*1

PUR hotmelt glue provides the best page spread compared to traditional EVA hotmelt glue. High binding strength allows for the application of a small amount of glue, allowing the pages to lay flat when the book is opened.*1



EVA

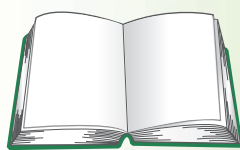

PUR

(*1: Depends on the binding condition.)

Durable against Temperature

PUR hotmelt glue retains durability and flexibility in both high and low temperatures. The temperature resistance for PUR hotmelt glue ranges from -20 to 120 degrees Celsius versus 0 to 45 degrees Celsius for EVA hotmelt glue. This allows PUR bound books to be handled in almost any climate or location.

Ecology

PUR adhesive is environmentally friendly, allowing PUR-bound books to be recycled. PUR also has a lower melting point (120 degrees Celsius) than EVA for operational energy savings.

One to One Book Production

Variable Production Binder BQ-470 Variable

Book Thickness Input Caliper SI-470A Option

The SI-470A is used to measure the book block thickness and transfer the thickness information into BQ-470 Variable.



Features

1. The BQ-470 Variable is the best suitable perfect binder to enable you to produce one-to-one ultra short-run book.
2. Each clamp and all book thickness related adjustments are made automatically in just seconds.
3. Book thickness information is entered via the Horizon SI-470 integrated caliper.
4. For longer production runs the BQ-470 Variable is capable of operating at a cycle rate of 1,350 per hour.
5. Existing machines are easily upgradeable in the field by adding optional V-470S variable production software and SI-470 book thickness caliper.

Manage your bindery with JDF enabled control system.

pXnet System Option



The Horizon pXnet Bindery Control System is used as a central control point to schedule work, send job data to each finisher, monitor status of finishers and collect production statistics from finishers in real-time. pXnet brings efficiency and value in high-mix/low-volume production environments where frequent job changeovers are needed. The pXnet system can also be interfaced with an existing workflow for automated JDF set-up.

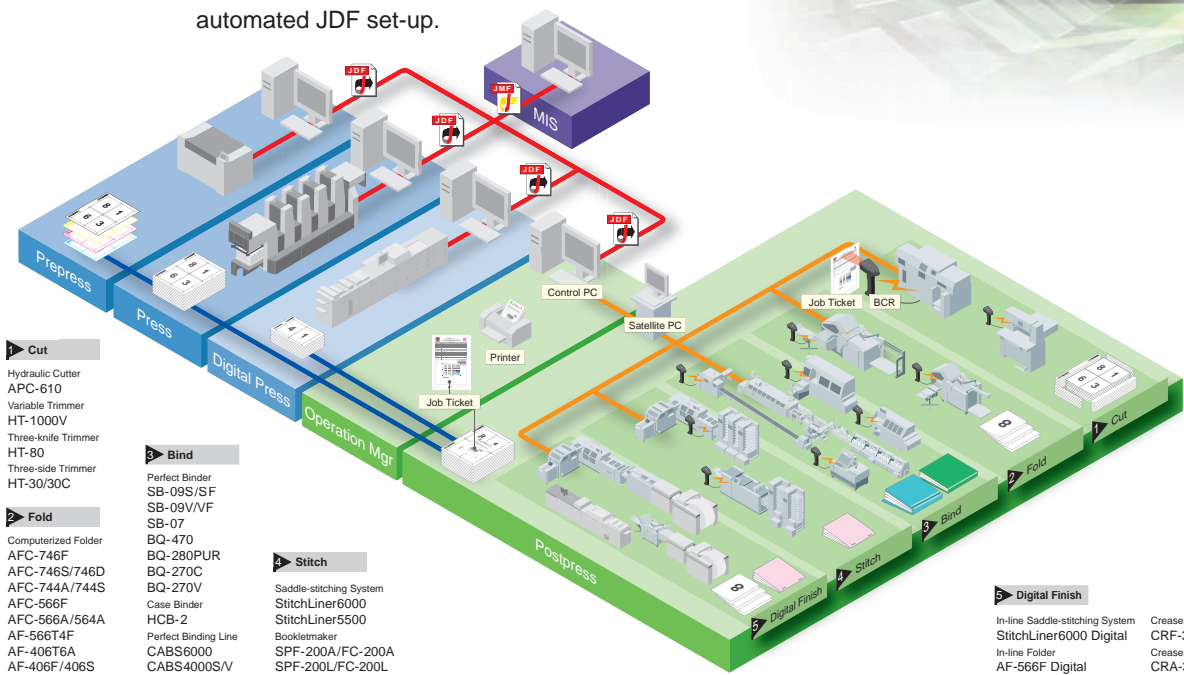

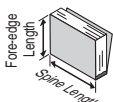
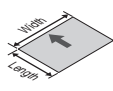
BQ-470 Major Specifications	
Binding Mode	Binding with milling, Binding without milling and Pad binding
Number of Clamps	4
Book Block Size	 <p>Top-Bottom x Fore-edge Max. 320 x 320 mm / 12.59" x 12.59" Min. 145 x 105 mm / 5.71" x 4.14"</p>
Book Thickness	1 to 65 mm / 0.040" to 2.560" (The book thickness can be limited depending on the sheet weight, book size and milling depth.)
Cover Size	 <p>Top-Bottom x Fore-edge Max. 320 x 660 mm / 12.59" x 25.98" (Up to 352 mm or 13.85" forwards from the clamp face.) (Up to 312 mm or 12.28" backwards from the clamp face.) Min. 135 x 225 mm / 5.32" x 8.86" (Up to 114 mm or 4.49" forwards from the clamp face.) (Up to 109 mm or 4.30" backwards from the clamp face.)</p>
Cover Weight Range	Bond Paper 81.4 to 302.4 gsm Coated Paper 104.7 to 348.9 gsm
Cover Stack Height	Max. 150 mm / 5.9"
Cycle Speed	Max. 1,350 cycles per hour (EVA)
	Max. 1,000 cycles per hour (PUR)
	When using the V-470S and the SI-470A : 190 to 670 books per hour (Production speed varies depending on the thickness of series of variable sheet count book.)
Voltage/Frequency	3-Phase 220 / 400 V, 50 / 60 Hz The external transformer is necessary for 220 V / 400 V.
Machine Dimensions	With delivery stacker (short type) and milling blower duct : W3,620 x D1,570 x H2,000 mm / W142.6" x D61.9" x H78.8"
	With delivery stacker (long type) and milling blower duct : W3,620 x D2,240 x H2,000 mm / W142.6" x D88.2" x H78.8"
	Without delivery stacker and milling blower duct : W3,220 x D1,090 x H2,000 mm / W126.8" x D43.0" x H78.8"

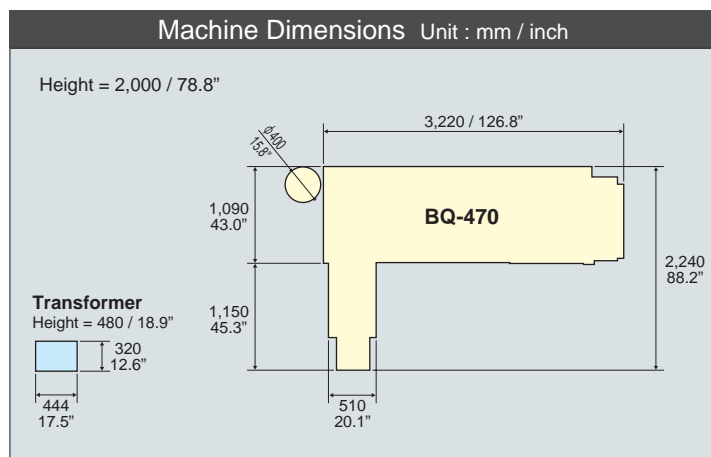

*The machine design and specifications are subject to change without any notice.

Distributed by

Options

■ SI-470A Book Thickness Input Caliper

The SI-470A is a book thickness measuring and input device for further operation efficiency.

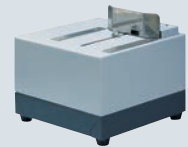

■ T-470 Weekly Timer

The T-470 weekly timer automatically switches power on at pre-set times for quick makeready. Time and day of the week can be set.



■ ET-470 Extra Table

The ET-470 is the additional table for installing the SI-470A or using as work table.



■ PM-470 Premelt Tank (18 liter)

The PM-470 is the premelt tank for EVA hotmelt glue.



■ L-470 Manual Simple Lifter

■ F-470 Fork for Lifter

The L-470 is a hand lifter for easy and safe tank replacement.
The F-470 fork is a custom-fit attachment to the lifter that holds the glue tank firmly in position for easy and safe tank replacement.

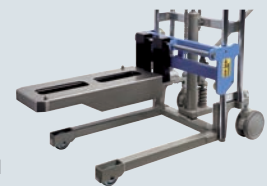

■ S-470 Stand for Melt Tank Unit

The S-470 stand is designed to receive and hold the glue tank unit after replacement.



■ M-470 Glue Melting Heater

The M-470 is a laboratory oven used to premelt the PUR hotmelt glue.



■ B-470 Teflon Coated Beaker

The B-470 Teflon coated beaker can be used to premelt the PUR hotmelt glue to refill the glue tank.



HORIZON INTERNATIONAL, INC.

510 Kuze Ooyabu-cho, Minami-ku, Kyoto, 601-8206, Japan Phone : +81-(0)75-934-6700, Fax : +81-(0)75-934-6708, www.horizon.co.jp